



# Weather Louvres



Certificate Number 26789  
ISO 9001  
ISO 14001  
ISO 45001





Contemporary looks,  
enhanced by improved  
performance. We are  
proud to be leading edge.

## Our distinctive & efficient Weather Louvre system

---

Aerodynamic with high resistance to weather that's easy to assemble with our optional integrated steel work support system.

### Visually attractive and versatile

Enhance your buildings appeal with our distinctive weather louvres disguising your unsightly plant. Balancing weather efficiency with aerodynamic performance protects your ventilation openings.

Being the only company in the UK that manufactures Weather Louvres, Continuous Line Acoustic Louvres and Attenuators in-house we will recommend the best performing and most cost efficient solution for your project.

### One multi-purpose system with many applications

Weather Louvre applications include: fresh air intakes and exhausts for ventilation systems, mechanical equipment screens or enclosures, natural ventilation and façade cladding, all providing a seamless look wherever they are used.

For a totally individual appearance, the Weather Louvres are fabricated from extruded aluminium and can be finished in polyester powder paint to a wide range of RAL colours.

### You can be confident in our performance testing

We like to do things properly and our Weather Louvre range has therefore been rigorously tested to offer performance data that you can trust. Applicable standards -

Rain Penetration, Pressure Drop and Coefficient of Entry – BS EN ISO 13030: 2001 (BSRIA). More detail on this test standard is available upon request.

### Class A rainwater penetration

Rainwater will penetrate into a building through standard Weather Louvres. So we have developed a high performance option to achieve Class A rainwater penetration when tested at BSRIA (99% effective at 2.5m/s face velocity).

**100%**  
Be 100% confident in the  
quality and performance of  
our products



## Supporting you every step of the way

---

We are always delighted to answer your questions and provide you with detailed specifications, design and pricing. If you have a complex project then we can develop products or design solutions to meet your specialist needs with our bespoke service.



Partner with **experts who understand you and your market**

---

### Beautifully designed

All our contracts are drawn by skilled technicians, using AutoDesk Inventor, building accurate 3D models of the products, so all elements fit perfectly with each other and your building.



### Continuous investment in automated manufacturing

Advanced technology is central to our Production facilities in Dorset. From automated engineering of component parts to high quality polyester powder painting for a durable and long lasting finish. We hate waste of all kinds and so continuously drive them out. Guaranteeing you the highest quality products, achieving your expectations and all delivered at the lowest possible cost.

### Accurate installation, on time and budget

Our highly trained project managers will work with you to ensure our products are installed on time and to budget, even for the most challenging of projects.

The innovative assembly design of our Weather Louvres makes installation faster, helping to save vital time on site.

**5%**

Material waste is down below 5% thanks to our unique software. All unused aluminium is recycled

# Weather Louvre applications

Our engineers will recommend the best solution for your project based on your specific application and requirements. Whether natural or mechanical ventilation is required, or if unsightly buildings or plant need 'hiding' from view.

The geographical location and height above sea level will also determine exposure to weather and wildlife which may require added protection.

Whatever your challenges, we'll have you covered.

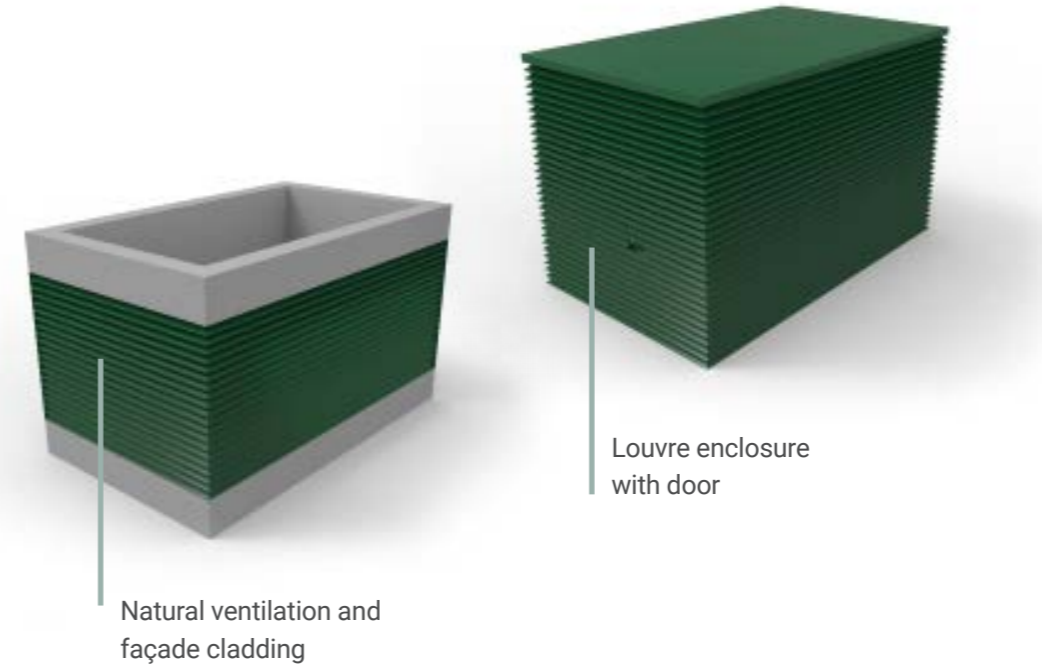
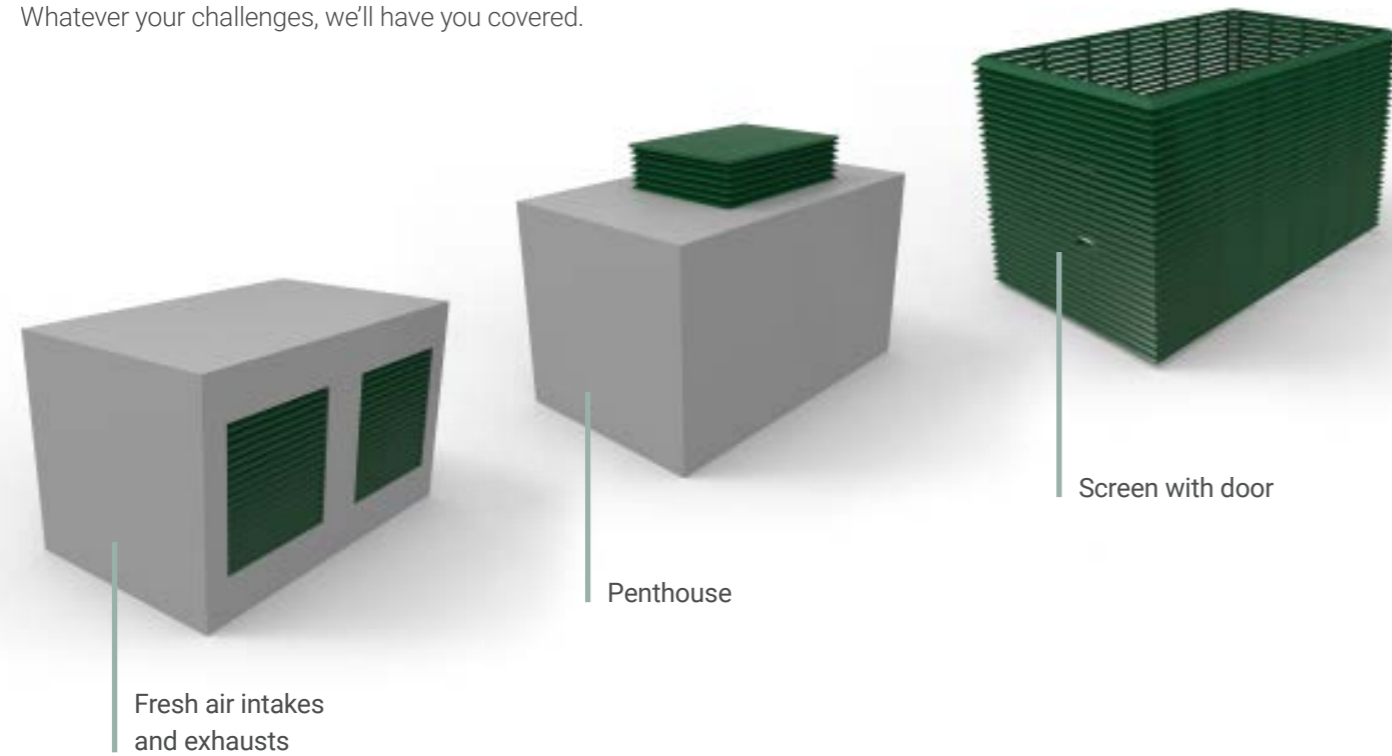

With a robust aluminium profile this PLS 100 blade is commonly used for industrial purposes and large areas of louvre façade. It is especially useful for plant screening, and when inverted this louvre provides screening of the plant when viewed from below.

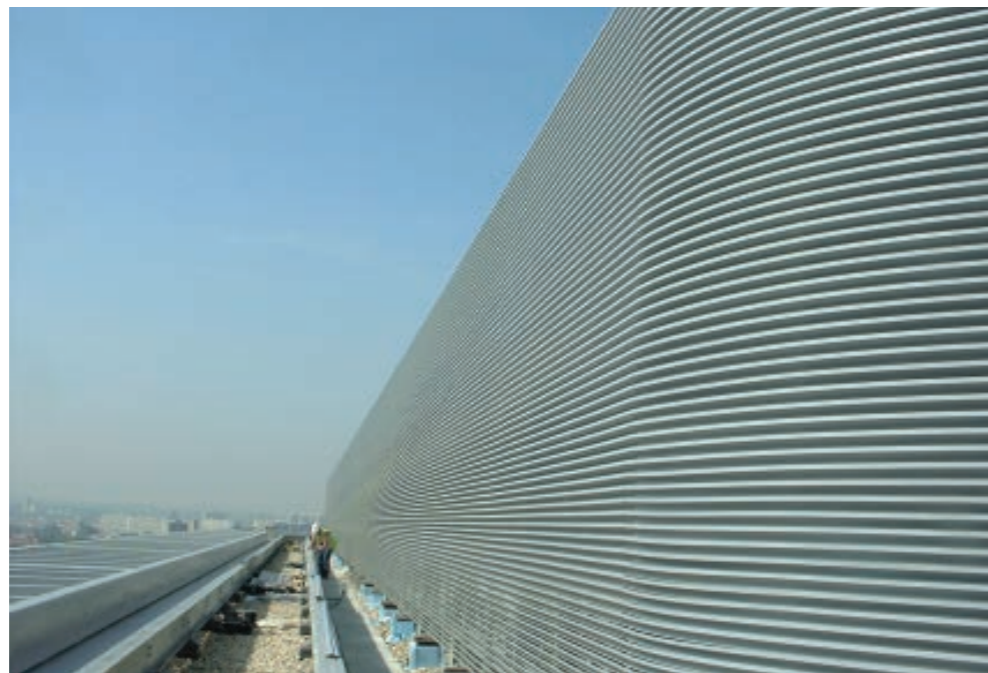

## Weather Louvre doors

Doors are available as both single and double leaf. There's an extensive range of furniture options to meet both your safety and security requirements. They are offered for active airflow or provided as dummy profiles with blanking.

# Consider the weather

Louvre systems are designed to allow air to pass through the façade, either for inlet or outlet air ventilation requirements.

It is possible that under certain weather conditions, airborne rain will manage to pass through the louvre bank. The application of the louvre system and the prevailing circumstances will determine the severity of this issue. There are classifications in BS EN ISO 13030: 2001 to provide guidance for selecting the right louvre for your project in regards to the rain ingress. Panels of louvre are trialed on simulated rain test rigs, and are then classified in terms of their effectiveness at preventing rain from passing through the panel.

If it is highly important that rain is prevented from passing through the louvre system, a higher classification louvre should be selected, such as 'Class A'.

Penetration classes		
Class	Effectiveness	Maximum allowed penetration of simulated rain l/h.m <sup>2</sup>
A	1 to 0.99	0.75
B	0.989 to 0.95	3.75
C	0.949 to 0.80	15.00
D	Below 0.8	Greater than 15.00

Source: BS EN ISO 13030: 2001



## Penetration classes

The simulated wind and rain that the weather louvre is subjected to under the standard test is as follows:

- ✓ Fan driven wind at a speed of 13 m/s (approximately 30mph)
- ✓ Water sprayed as rainfall at a rate of 75 l/h.

The amount of water collected behind the louvre is compared to that of a similar test conducted with the louvre removed completely. The effectiveness is the proportion of water rejected by the louvre.

The louvre under test is 1m x 1m in size and provides useful comparative data between different design profiles. It does not necessarily replicate the most severe of weather conditions or qualify the need for appropriate water collection and drainage.

# Resistance to air flow

## Entry or discharge loss coefficient classes

The coefficient of discharge ( $C_D$ ) or entry ( $C_E$ ) compares the performance of the louvre against an ideal louvre with minimal air resistance. It is expressed as a single class based on an average result of the tests measuring the pressure differential between the outside and inside of the louvre, giving the resistance to airflow. The air resistance is rated in classes, with '1' indicating the least resistance and '4' the most.

Entry or discharge loss coefficient $C_D$	
Class	Entry or discharge loss coefficient $C_D$
1	0.4 to 1.0
2	0.3 to 0.399
3	0.2 to 0.299
4	0.199 and below

Source: BS EN ISO 13030: 2001

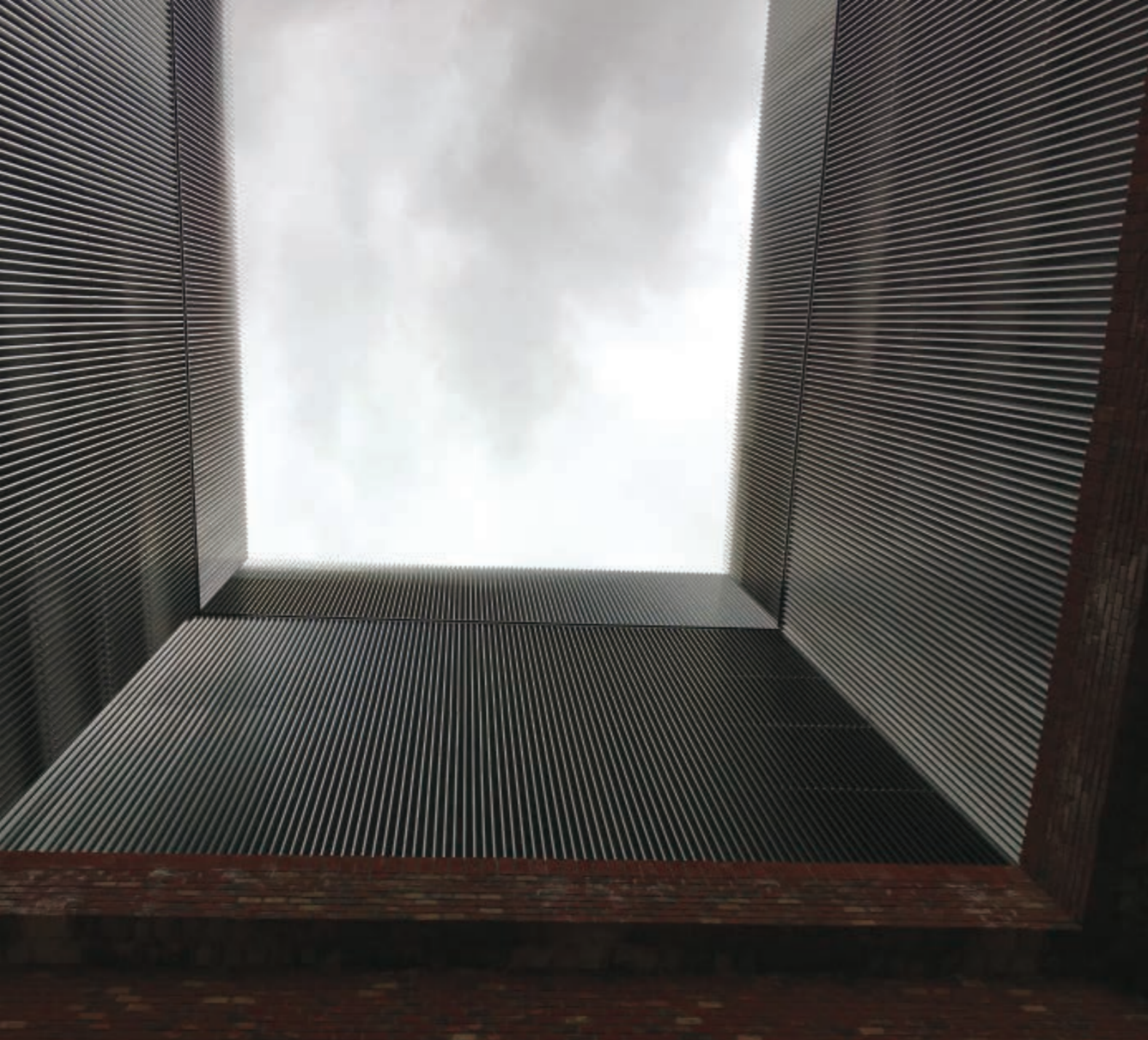

## VertiBlade – created with designers and architects in mind

We were asked by an architect to help solve an issue with a new building on the Greenwich Peninsula in London. They calculated that the inherited steel work structure would not support the full weight of the brick work all the way to the top of the building and the architect's client wanted the sub-station transformers on the roof to be completely out of sight of the nearby school and residential properties.

### This light-weight cladding system solved all the issues on-site

Following a couple of meetings with the architect, we came up with the idea of using the **VertiBlade** system so that the transformers would not be seen and without adding a heavy load to the supporting wall structure. In effect, adding a light-weight, visually attractive form of pervious cladding, when viewed from different angles at ground level.

VertiBlade

#### CASE STUDY

## Greenwich Peninsula Sub-station

London

During the day, our **VertiBlade** provides a high definition profile, with crisp, clean lines and striking colour changes as the sunlight catches them. At night, this complete 3D screening to plant can turn into a light feature with an appropriate LED light system.



### A detailed assessment was carried out by our acoustic experts

As the building was originally all brickwork there was no issue with noise breakout from the transformers. Acoustic experts at LCP, our sister company, carried out a detailed assessment of the plant to ensure that the noise levels at the school and residential properties were not going to be exceeded with the blade system proposed.

A meeting on-site with the local planners was arranged, where colour samples of the blades were handed over. The black ones, matching the colour of an adjacent building along with the results from the acoustic assessment, were subsequently approved in a new planning application.



### A bespoke 3D corner section maintains the aesthetic appearance

Due to the way that the building had been designed, we developed a bespoke way of fixing the **VertiBlade** to the existing steel system that would align with the concrete stairwells at the end of the building. A special 3D section was also designed to create a crisp corner detail enhancing the aesthetic appearance of the system.

Because of the tight proximity of the site within its boundaries, it was crucial that the access equipment had the appropriate height and reach to deliver the installation contract.

VertiBlade



### A very happy client

**Our client said afterwards,** “the high level cladding has now been completed and Caice has undertaken a fantastic job. The detailing is crisp and all of the lines are straight and clean. Installing the top section the opposite way around has added definition to the profile and when the light catches it the colour changes are striking. I am very happy with the finished product.”

# Weather Louvre options

1

## How is the Weather Louvre system to be used

For plant screening our PLS100 provides the optimum solution and can be inverted should the viewing position be from below. For ventilation and rain defence our PLS 50 and PLS 50HP offer solutions to meet your needs.

2

## Mullion and Purlin support

Selected to match the blade profile and structural requirements.

3

## Optional panels fitted behind the Weather Louvres

These options will make your building work better and help to match your specific requirements.



4

## Fully integrated steelwork support system

We have developed a fully integrated steelwork support system to enable easy installation of our Weather Louvres for screening applications, enclosures or within large building apertures. Calculations can be provided to ensure structural and wind loading requirements are achieved.

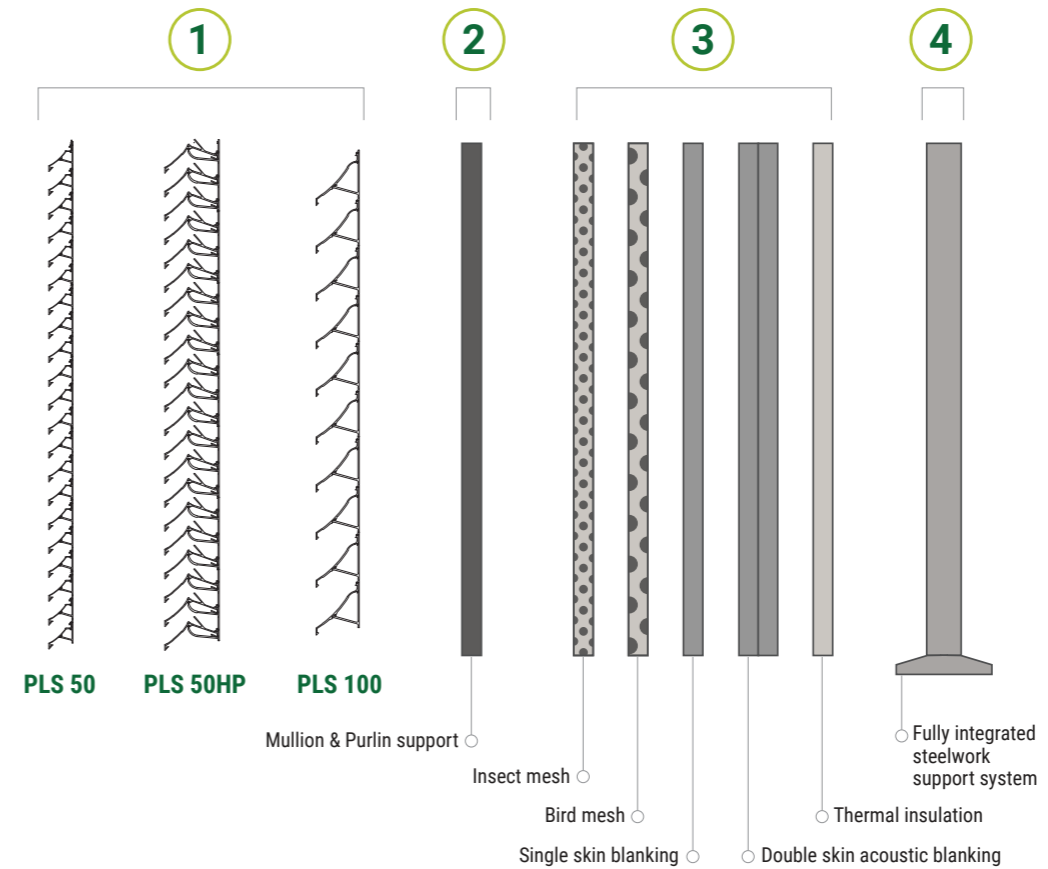

## Weather Louvre blade profile view



Mullion options		
Mullion type	Blade/Mullion	Mullions maximum unsupported height
M50	100mm	1,600mm
M55	105mm	2,000mm
M82	132mm	3,000mm

Mullion options		
Mullion type	Blade/Mullion	Mullions maximum unsupported height
M50	160mm	1,600mm
M55	165mm	2,000mm
M82	192mm	3,000mm

Mullion options		
Mullion type	Blade/Mullion	Mullions maximum unsupported height
M50	140mm	1,600mm
M55	145mm	2,000mm
M82	172mm	3,000mm

The overall depth of the louvre including the blade, mullion, purlin and supporting steelwork will be dependant on the on-site installed condition, taking into account factors such as wind loading and building structure.



**We're pioneers.** Partnering with you to lead our industry, by creating the best products and structuring our business around you. Sharing our knowledge, embracing new ways of working using the latest technologies and being careful of our environment.

# PLS 50 Weather Louvre Technical Data



## Weather Louvre, Standard 50mm Pitch Profile, 50mm Blade Depth

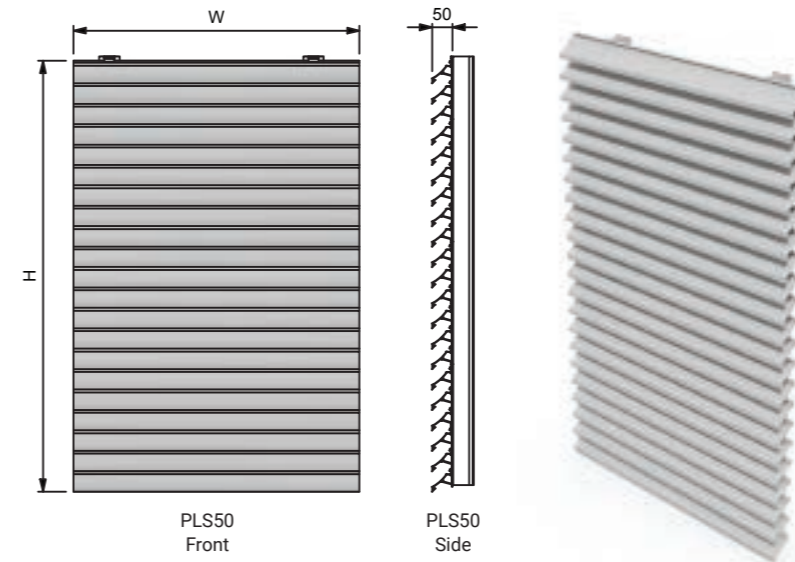

Typical weight with 50mm mullion at 1 metre centres – 16kg/m<sup>2</sup>

Generally louvres will be supplied in component parts for assembly on site. Joining brackets and fixings will be provided for assembly.

Installation services, support steelwork, flashings, fixings to the structure and mastic will not be provided unless stated.

Refer to the Weather Louvre Schedule and Product Code Definitions for the size and specification of each Weather Louvre.

A minimum of 10mm clearance should be allowed between the structure and the Weather Louvre sizes shown.

## Performance

### Resistance to Airflow (C<sub>e</sub>)

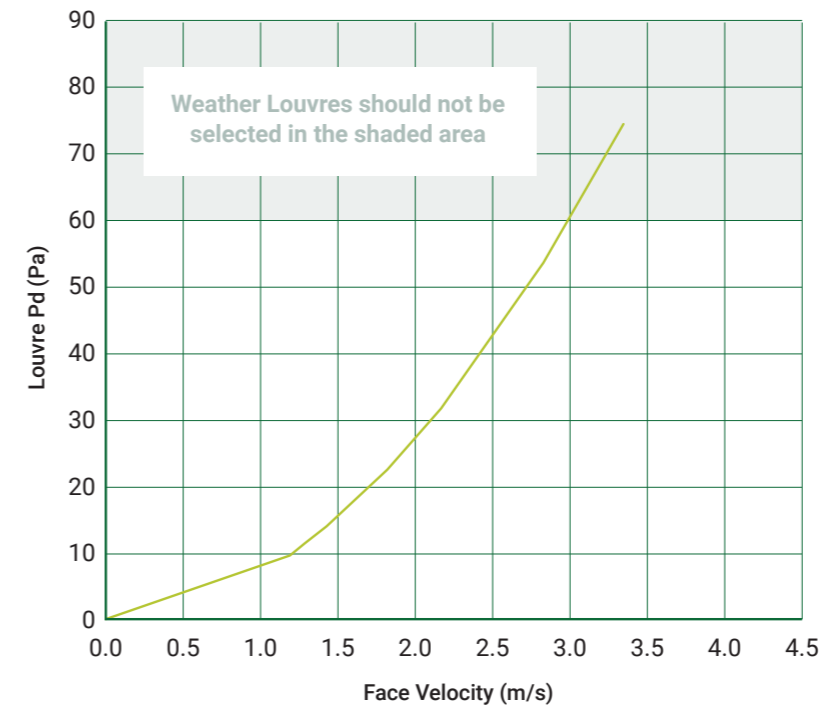

Physical Free Area: 58%  
Intake Coefficient C<sub>e</sub>: 0.308  
Intake Coefficient Class: 2

Rainwater Penetration Class		
Velocity	Effectiveness	Class
0.0	97.2%	B
0.5	95.9%	B
1.0	94.7%	C
1.5	90.9%	C
2.0	82.4%	C
2.5	64.2%	D

**Material:** Aluminium Extrusion  
**Finishes:** Mill, Natural Anodised, Polyester Powder Paint to a range of RAL colours  
**Insect/Bird Mesh:** Provided as requested  
**Doors:** Single and Double leaf with furniture to meet safety and security requirements.

# PLS 50HP Weather Louvre Technical Data



## Weather Louvre, High Performance 50mm Pitch Profile, 110mm Blade Depth

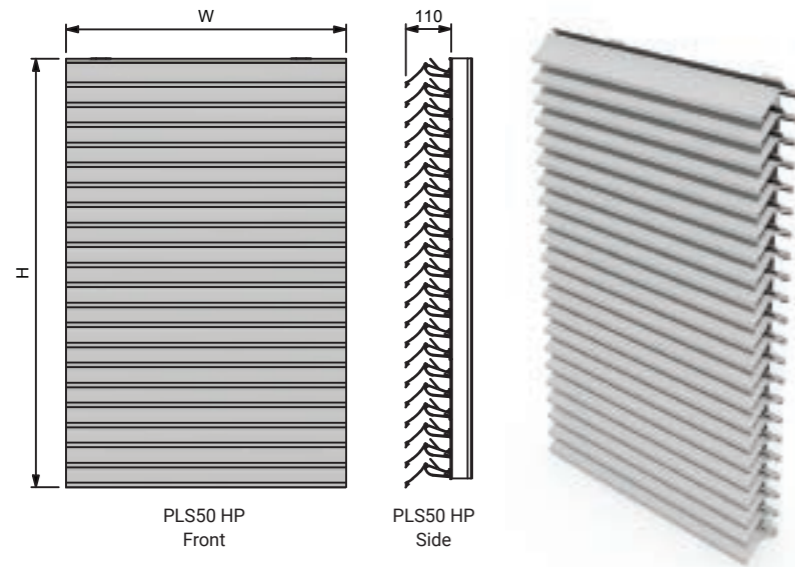

Typical weight with 50mm mullion at 1 metre centres – 36kg/m<sup>2</sup>

Generally louvres will be supplied in component parts for assembly on site. Joining brackets and fixings will be provided for assembly.

Installation services, support steelwork, flashings, fixings to the structure and mastic will not be provided unless stated.

Refer to the Weather Louvre Schedule and Product Code Definitions for the size and specification of each Weather Louvre.

A minimum of 10mm clearance should be allowed between the structure and the Weather Louvre sizes shown.

## Performance

### Resistance to Airflow (C<sub>e</sub>)

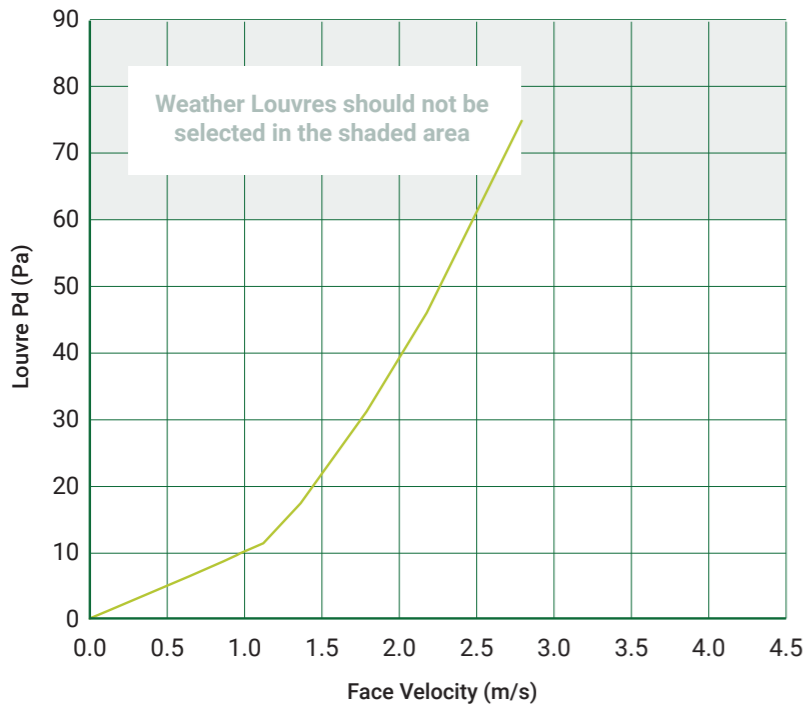

Physical Free Area: 50%  
Intake Coefficient C<sub>e</sub>: 0.256  
Intake Coefficient Class: 3

Rainwater Penetration Class		
Velocity	Effectiveness	Class
0.0	100%	A
0.5	100%	A
1.0	100%	A
1.5	100%	A
2.0	100%	A
2.5	99.4%	A

**Material:** Aluminium Extrusion  
**Finishes:** Mill, Natural Anodised, Polyester Powder Paint to a range of RAL colours  
**Insect/Bird Mesh:** Provided as requested  
**Doors:** Single and Double leaf with furniture to meet safety and security requirements.

# PLS 100 Weather Louvre Technical Data



## Weather Louvre, Standard 100mm Pitch Profile, 90mm Blade Depth

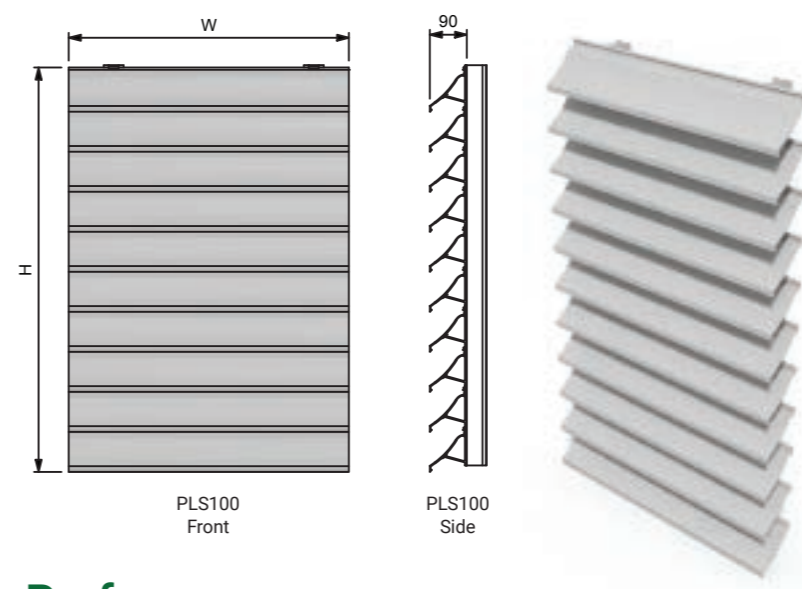

Typical weight with 50mm mullion at 1 metre centres – 18kg/m<sup>2</sup>

Generally louvres will be supplied in component parts for assembly on site. Joining brackets and fixings will be provided for assembly.

Installation services, support steelwork, flashings, fixings to the structure and mastic will not be provided unless stated.

Refer to the Weather Louvre Schedule and Product Code Definitions for the size and specification of each Weather Louvre.

A minimum of 10mm clearance should be allowed between the structure and the Weather Louvre sizes shown.

## Performance

### Resistance to Airflow (C<sub>e</sub>)

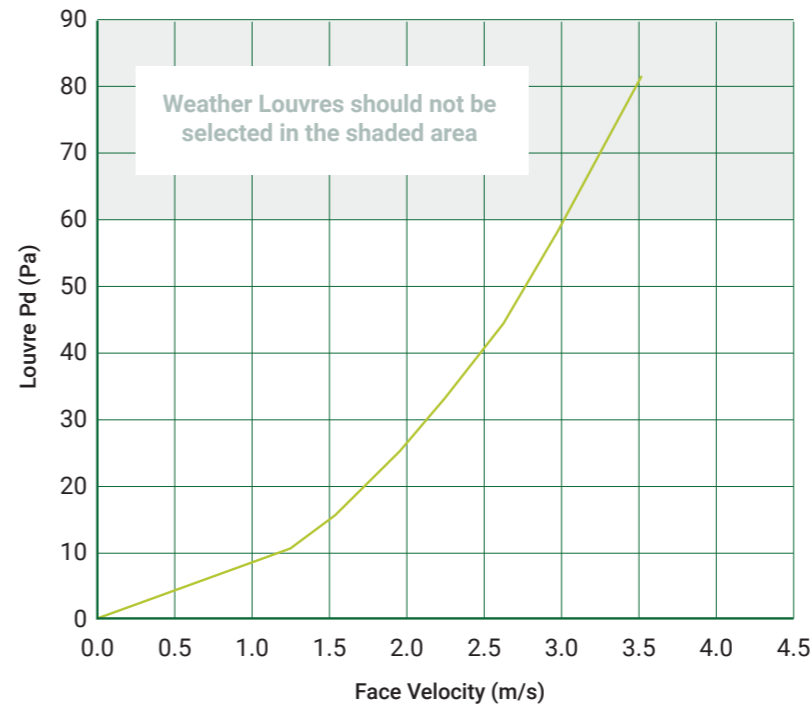

Physical Free Area: 55%  
Intake Coefficient C<sub>e</sub>: 0.294  
Intake Coefficient Class: 3

Rainwater Penetration Class		
Velocity	Effectiveness	Class
0.0	96.02%	B
0.5	93.5%	C
1.0	91.4%	C
1.5	85.5%	C
2.0	75.3%	D
2.5	56.6%	D

**Material:** Aluminium Extrusion  
**Finishes:** Mill, Natural Anodised, Polyester Powder Paint to a range of RAL colours  
**Insect/Bird Mesh:** Provided as requested  
**Doors:** Single and Double leaf with furniture to meet safety and security requirements.

# Specifying the Weather Louvre system

## Weather Louvre specification

We're here to help and can provide a detailed Weather Louvre specification for inclusion within the overall specification for your project. This is also available in a short form NBS Specification format if required.

t: +44 (0)118 918 6470

f: +44 (0)118 918 6480

enquiries@caice.co.uk

caice.co.uk



### Head office & registered office

Riverside House, Unit 3, Winnersh Fields  
Wokingham, Berkshire  
RG41 5QS

### Northern region sales office

Ground Floor, Units C - E  
Toller Court, Short Bank Road  
Skipton, North Yorkshire  
BD23 2HG

### South west region sales office

Bank House, Bath Road  
Chippenham, Wiltshire  
SN15 2SA



Certificate Number 26789  
ISO 9001  
ISO 14001  
ISO 45001



### Middle East Office Bahrain

Office 801, Eighth Floor,  
Address Tower, Building 655,  
Road 3614, Al Seef Area 0436,  
Kingdom of Bahrain

### Middle East Office Saudi Arabia

Level 29, Olaya Towers,  
Tower B, Intersection of Olaya Street  
and Mohammed Bin Abdul-Aziz Street,  
Riyadh, 11523, KSA

